

# Compact Dial Gage Stand

## With Cast Iron Base

- Rugged enamelled cast iron base
- Full ground working surface
- Fine adjustment knob
- • Can be used with any AGD 1, 2, 3 or 4 dial indicator
- Dial Indicator and Ceramic Working Plate are optional
- Prices don't include ceramic working plate and dial indicator.



Style I



Style III



Style IV



Style II

STC#	Base Size	Flatness	Customer #
CMI0525-10	□3-1/8" (□80mm)	3um (0.0001")	
CMI0525-11	6" x 4-3/8"	3um (0.0001")	
CMI0525-12	7-1/4" x 5-1/8"	3um (0.0001")	
CMI0525-13	5-1/2" x 4-1/8"	3um (0.0001")	

## Economy Magnetic Bases

- Accept all AGD dial indicators
- Accept lug backs groups 1,2,3 & 4
- Fine permanent magnet
- Smooth & easy on/off switch
- Horizontal & vertical positioning capability
- Chrome rods & column
- Enamel finish
- V-grooved base for ease of mount on cylindrical parts
- Light duty and heavy duty styles are optional.
- **We can also supply dial indicator.**



Description	STC#	Approx. Pull	MSC#
Light Duty	CMB0005	110 Pounds	06580013
Heavy Duty	CMB0005-1	140 Pounds	06580369

## Flexible Magnetic Base

- Fine permanent magnet
- Smooth & easy on/off switch
- Horizontal & vertical positioning capability
- Chrome rods & column
- Enamel finish
- V-grooved base for ease of mount on cylindrical parts
- Base size: 2" x 2" x 2-1/2" with on/off switch.
- 12" long flexible arm (Overall length: 14")
- **We can also supply dial indicator.**



Description	STC#	Approx. Pull	MSC#
Magnetic Base	CMB0003	110 Pounds	06580070

## Fine Adjustment Magnetic Bases

- Accept all AGD dial indicator backs
- Accept lug backs groups 1,2,3 & 4
- Top Quality
- Easy tune fine adjustment
- Fine quality permanent magnet
- Smooth & easy on/off switch
- Horizontal or vertical positioning capability
- Chrome plated rods & column
- V-grooved base for mounting on cylindrical parts
- Fine wrinkle enamel finish
- Superior quality knobs
- Light duty and Heavy duty styles are optional.
- **We can also supply dial indicator.**



Description	STC#	Approx. Pull	MSC#
Light Duty	<b>CMB0006</b>	<b>110 Pounds</b>	06580039
Heavy Duty	<b>CMB0006-1</b>	140 Pounds	06580377

## Universal Type Magnetic Bases

**Unique Hydraulic Clamping System Can Hold All Style Dial and Dial Test Indicator.**

- Fine permanent magnet
- Smooth & easy on/off switch
- Horizontal & vertical positioning capability
- Chrome rods & column
- Enamel finish
- V-grooved base for ease of mount on cylindrical parts
- Base size: 2" x 2" x 2-1/2" with on/off switch.
- Overall length: 12".
- **We can also supply dial indicator.**



Description	STC#	Approx. Pull	MSC#
Magnetic Base	<b>CMB0002</b>	80 kg	06580070

# Granite Base Comparator Stands

## With Fine Adjustment Knuckle on Clamp

- Highest quality, black granite base
- Flatness is .0.00008” (2um)
- Accepts AGD 1, 2, 3 and 4 indicators
- Extremely stable and durable
- Dial Indicator and ceramic working plate are optional.
- Prices don't include dial indicator and ceramic working plate.
- Adjustment of Style I is made of Casting



Style I

Adjustment of Style II is made of alloy steel and hardened.

Style III and Style IV have thread rod, so it is easy to operate. But adjustment of Style IV is longer. Also, Style III and Style IV have different base size.

Style V has a T-Slot on the surface of base.

Description	STC#	Size	Customer #
Style I	CMI0525-1	6” x 6” x 2”	
Style I	CMI0525-2	8” x 8” x 2”	
Style II	CMI0525-3	6” x 4” x 1-1/2”	
Style II	CMI0525-4	8” x 6” x 2”	
Style III	CMI0525-5	8” x 6” x 2”	
Style IV	CMI0525-6	12” x 8” x 2”	
Style V	CMI0525-7	24” x 18” x 4”	
Hex Stand	CMI0525-8	□ 8” (□200mm)	
Circle Stand	CMI0525-9	□ 8” (□200mm)	

# Heavy-Duty All Purpose Magnetic Base Indicator Holder

- Furnished with one main post and two separate bars for maximum flexibility. Complete with fine adjustment attachment.
- Accepts all AGD Dial indicators with stems of 5.32 and 3.8 diameter. Has on-off switch to facilitate mounting on any steel surface.
- Easy tune fine adjustment
- Fine quality permanent magnet
- Horizontal or vertical positioning capability
- Chrome plated rods & column
- V-grooved base for mounting on cylindrical parts
- Fine wrinkle enamel finish
- Superior quality knobs

## Specifications:

- Length - 2.36
- Width - 1.90
- Height - 2.00
- Magnetic Pull - 110 Lbs.
- Main Post - .79 x 7.25
- One Bar - .55 x 6.5
- One Bar - .39 x 5
- **Dial indicator is optional.**

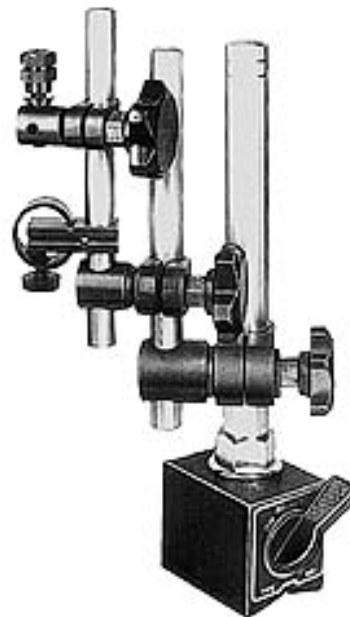

Description	STC#	Approx. Pull	MSC#
Magnetic Base Only	<b>CMB0004</b>	60 kg	06580351

# Multi-Use Magnetic Base

This quality import features tough holding power. The universal design features five different locations for mounting accessories.

- Zinc die cast housing
- Size approx. 41.2 x 1 x 11.4
- A universal magnetic base
- Dial indicators is optional.



Description	STC #	MSC#
Magnetic Base Only		76580455
Base with .500" Dial		76580463
Base with 1.000" Dial		76580471
Base with 2.000" Dial		76580489

## Accessory for Dial Indicator

### Magnetic Back

Adapted for all AGD dial indicator

**STC#**

**MSC#: 06450555**





## Zero-Set Indicator Set

“Zero-Set” functions as a quick and practical work positioning device. Setting up a workpiece before machining, or aligning the center of a round workpiece in relation to the cutting head, takes virtually no time with “Zero-Set.” The hardened clamping post consists of three O.D.’s, from top, 1/4”, 3/8” and 1/2” and has hardness of approximately 58 to 60 Rockwell C.



The illustration indicates the alignment of a workpiece in relation to the cutting head. It reaches anywhere within a 8” diameter and fine-adjusts about 3/8” with a large knurled knob. “Zero-Set” can also be adapted to Transfer Stands for closer control of the Test Indicator (in the horizontal direction). Zero-Set & Indicator Shown are sold separately.

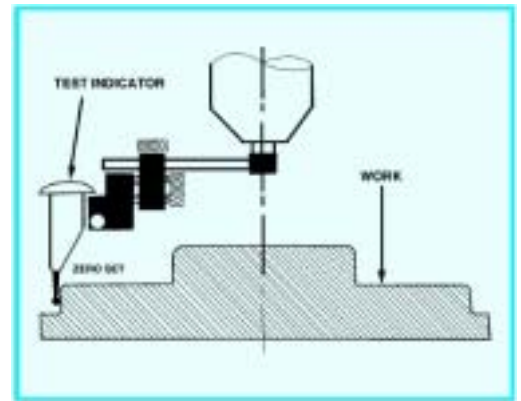

Description	STC #	MSC #
Zero-Set for Test Indicator	<b>CMI0390</b>	06451470

## Indicator Holder

For Dovetail and 5/32” stem indicator



Rectangular Holder  
with 1/4" x 1/2" shank

**MSC# 06451637**



Half Round Combination Holder  
with two point adjustment & 1/4" Shank

**MSC# 16451645**